

BOUNDARY AND TOPOGRAPHIC SURVEY
PART OF RUSSIA TOWNSHIP ORIGINAL LOT NO. 86
AND PART OF ORIGINAL PLATS OF OBERLIN AS
RECORDED IN VOL. 1 P. 18 AND VOL. 5 P. 30
CITY OF OBERLIN, COUNTY OF LORAIN, STATE OF OHIO

KS ASSOCIATES
KS Associates, Inc.
260 Burns Road, Suite 100
Elyria, OH 44035
P 440 365 4730
F 440 365 4790
www.ksassociates.com

DATE	DESCRIPTION	BY

DATE: _____
DRAWN BY: _____
CHECKED BY: _____
DATE: _____
SCALE: 1" = 30'

NOTES:
1. RESURVEY SURVEY PERFORMED BY KS ASSOC. INC. AND PROVIDED TO WEST & ASSOCIATES BY OWNER.
2. UTILITY LOCATIONS HAVE BEEN PROVIDED TO WEST & ASSOCIATES BY THE OWNER AND SHALL BE VERIFIED IN FIELD PRIOR TO CONSTRUCTION.

REVISIONS:

NO.	DATE	DESCRIPTION

JOB NO. 06043-08
SHEET 2 OF 3

OBERLIN, OHIO
2012 Release Candidate Name

OBERLIN COLLEGE GATEWAY BUILDING

SITE SURVEY DRAWING

Drawn By: JBO
Checked By: CUN
Project Number: 2012007

Sheet Number: **C1.0**



SCF Solomon Cordwell Buenz
www.scb.com
Chicago 312.898.1100
San Francisco 415.218.2400

NERP ASSOCIATES
11100 N. Central Expressway, Suite 100
Dallas, TX 75243
Tel: 972.382.1100

Architecture Planning Interior Design

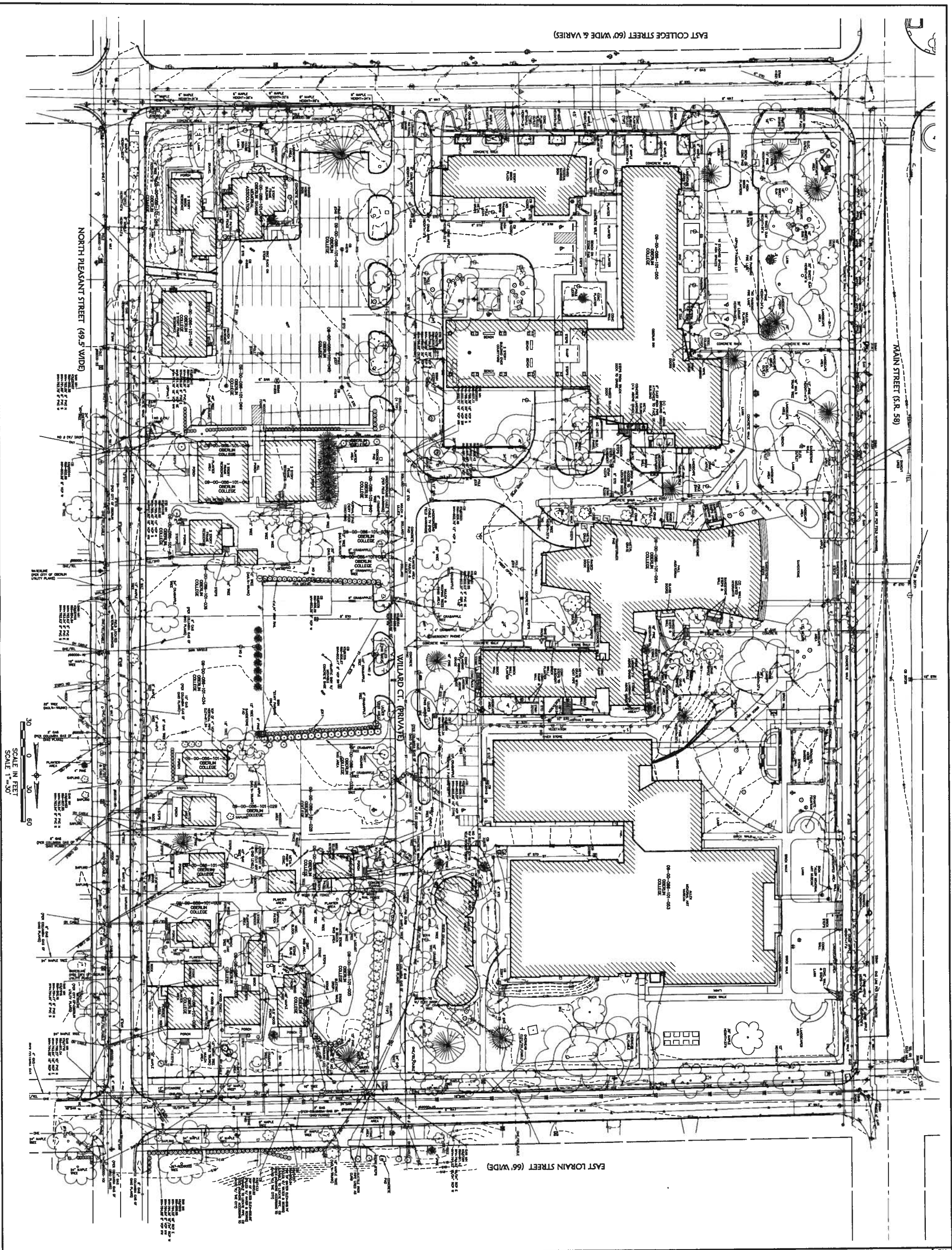

SCALE IN FEET
SCALE 1"=50'

BOUNDARY AND TOPOGRAPHIC SURVEY
 PART OF RUSSIA TOWNSHIP ORIGINAL LOT NO. 86
 AND PART OF ORIGINAL PLATS OF OBERLIN AS
 RECORDED IN VOL. 1 P. 18 AND VOL. 5 P. 30
 CITY OF OBERLIN, COUNTY OF LORAIN, STATE OF OHIO

KS Associates, Inc.
 260 Burns Road, Suite 100
 Elyria, OH 44035
 P 440 365 4730
 F 440 365 4790
 KS ASSOCIATES www.ksassociates.com

DATE: _____
 DRAWN BY: _____
 CHECKED BY: _____
 DATE: _____
 REVISIONS

REVISIONS	DATE	DESCRIPTION	BY

JOB NO. 0604-08
 SHEET 2 OF 3

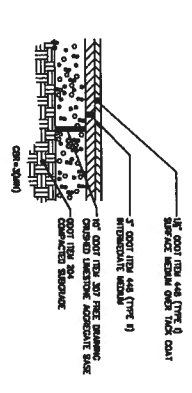

1 HEAVY DUTY ASPHALT PAVEMENT
NOT TO SCALE

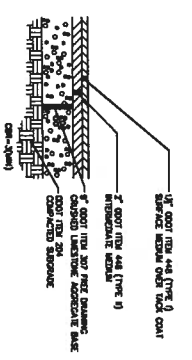

2 STANDARD DUTY ASPHALT PAVEMENT
NOT TO SCALE

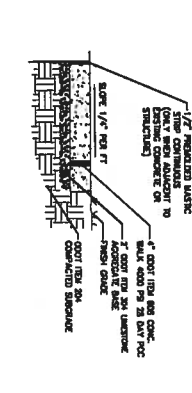

3 CONCRETE SIDEWALK
NOT TO SCALE

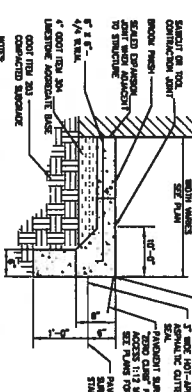

4 CONCRETE INTEGRAL CURB AND WALK
NOT TO SCALE

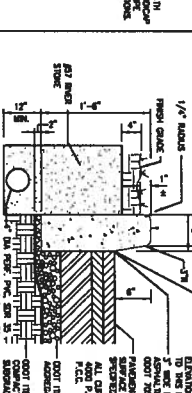

5 VERTICAL CONCRETE CURB
NOT TO SCALE

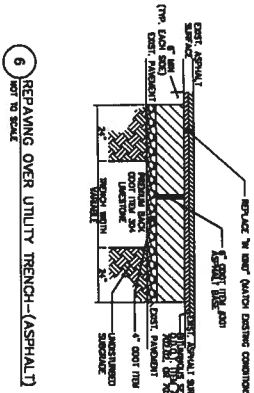

6 BEGINNING OVER UTILITY TRENCH (ASPHALT)
NOT TO SCALE

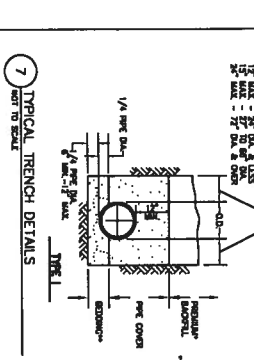

7 TYPICAL TRENCH DETAILS
NOT TO SCALE

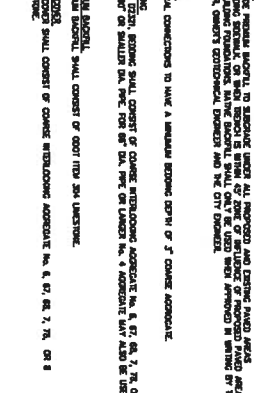

8 BOLLARD DETAIL
NOT TO SCALE

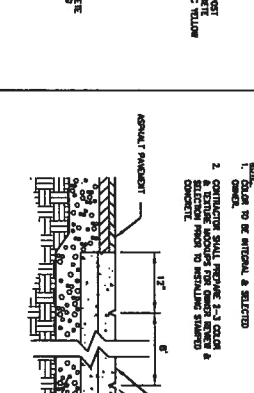

9 STAMPED CONCRETE SIDEWALK
NOT TO SCALE

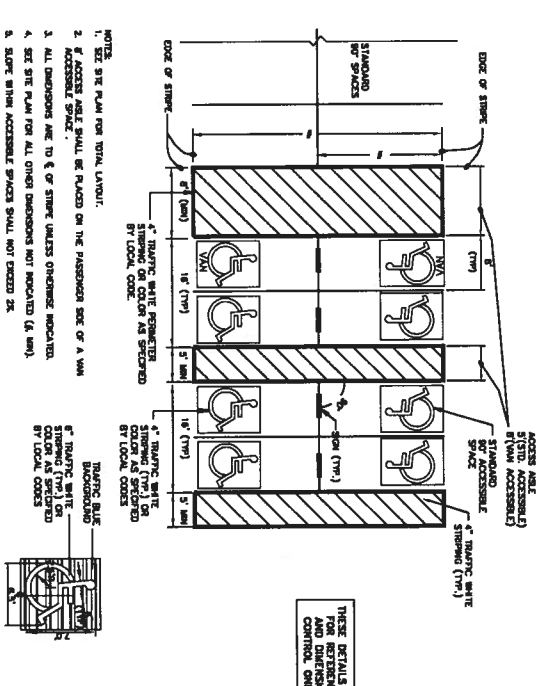

- NOTES:
- SEE SITE PLAN FOR TOTAL LAYOUT.
 - ACCESSIBLE SPACES SHALL BE PLACED ON THE PASSENGER SIDE OF A VAN ACCESSIBLE SPACE.
 - ALL DIMENSIONS ARE TO 6\"/>

10 ADA ACCESSIBLE PARKING DETAIL
NOT TO SCALE

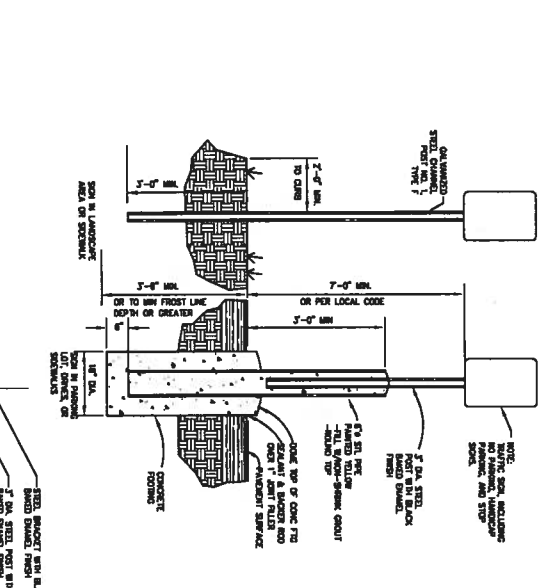

11 GENERAL PARKING SIGNAGE
PRESTANDARD

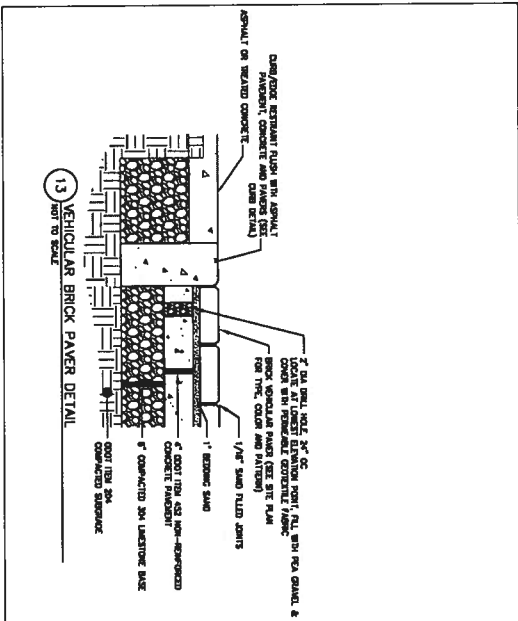

13 VEHICULAR BRICK PAVER DETAIL
NOT TO SCALE

NOTES:

- STANDARD PAVEMENT DIMENSIONS SHALL BE OBSERVED BY CONCRETE FINISHERS THROUGHOUT TO THE SHAPED SURFACE AND SHALL BE EXCEEDED FROM ADJACENT WALL.
- TRUCKED IN PAVEMENT SHALL BE PLACED ON THE BACK OF THE CURB AND SHALL BE EXCEEDED FROM ADJACENT WALL.
- REINFORCING STEEL SHALL BE PLACED IN THE CURB AND SHALL BE EXCEEDED FROM ADJACENT WALL.
- REINFORCING STEEL SHALL BE PLACED IN THE CURB AND SHALL BE EXCEEDED FROM ADJACENT WALL.

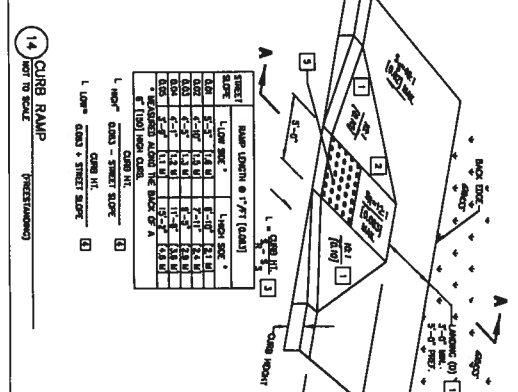

14 CURB RAMP
PRESTANDARD

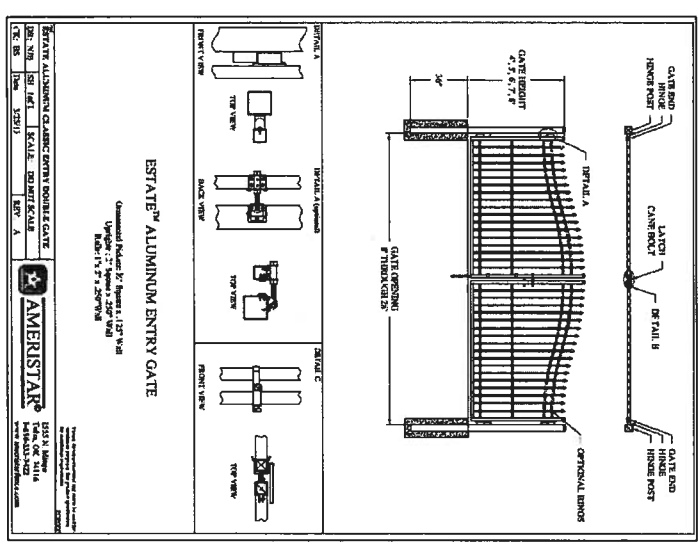

12 SWING GATE
PRESTANDARD

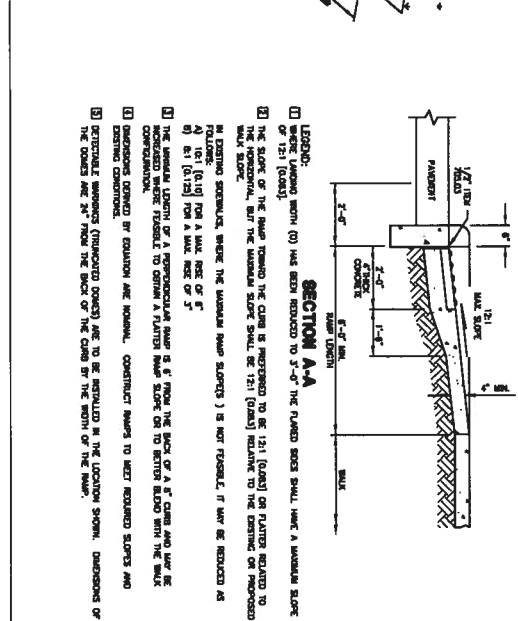

SECTION A-A
NOT TO SCALE

Legend:

- 1. 1/2\"/>

Notes:

- WHERE LINDERS WITH (D) HAS BEEN REDUCED TO 3\"/>
- THE STATE OF THE CURB SHALL BE 12:1 (GRADE) ON FLAT OR SLOPED TO THE SIDEWALK. THE MAXIMUM SLOPE SHALL BE 12:1 (GRADE) RELATIVE TO THE EXISTING OR PROPOSED FINISH GRADE. WHERE THE MAXIMUM SLOPE (S) IS NOT FEASIBLE, IT MAY BE REDUCED AS FOLLOWS:

SLOPE (S)	MAXIMUM SLOPE (S)
12:1	12:1
10:1	10:1
8:1	8:1
6:1	6:1
4:1	4:1

Additional Notes:

- THE MAXIMUM LENGTH OF A REINFORCING BAR SHALL BE 10' FROM THE POINT OF A 4\"/>
- REINFORCING STEEL SHALL BE PLACED IN THE CURB AND SHALL BE EXCEEDED FROM ADJACENT WALL.
- REINFORCING STEEL SHALL BE PLACED IN THE CURB AND SHALL BE EXCEEDED FROM ADJACENT WALL.

SITE DETAILS

Drawn By: JSD
Checked By: DLM
Project Number: 2012007

SCF Solomon Cordwell Buenz
www.scb.com
Chicago 312.886.1100
San Francisco 415.216.2400
Architectural Planning Interior Design

NERR NATIONAL REINFORCING ESTABLISHMENT RESEARCH & EDUCATION CENTER
www.nerr.org

SERVICE CONNECTION
Method 1 - New service connection

- NOTES:
 1. NEW WATER MAIN SHALL BE 12" DIA. UNLESS OTHERWISE SPECIFIED.
 2. ALL SERVICE CONNECTIONS SHALL BE MADE BY CITY ENGINEER.
 3. ALL SERVICE CONNECTIONS SHALL BE MADE BY CITY ENGINEER.
 4. ALL SERVICE CONNECTIONS SHALL BE MADE BY CITY ENGINEER.
 5. ALL SERVICE CONNECTIONS SHALL BE MADE BY CITY ENGINEER.

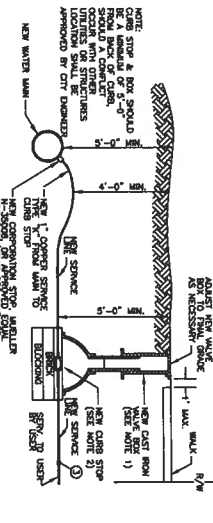

15 WATER SERVICE CONNECTION
(CITY OF GERRARD DETAIL)

WATERLINE TIE-INS TYPICAL PROCEDURES

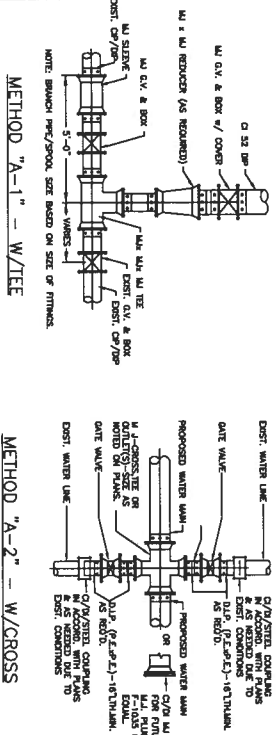

METHOD "A-1" - W/TIE
METHOD "A-2" - W/CROSS
 TIE-IN WITH NEW AND EXISTING CONSTRUCTION AT SAME ELEVATION

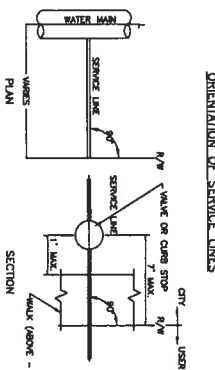

16 OPERATION OF WATER SERVICE LINES
(CITY OF GERRARD DETAIL)

INDUSTRIAL/COMMERCIAL SERVICE TAP

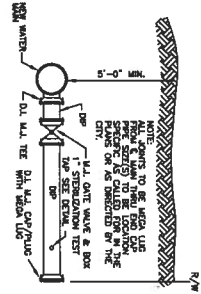

17 INDUSTRIAL/COMMERCIAL WATER SERVICE TAP
(CITY OF GERRARD DETAIL)

TRENCH & BEDDING DETAILS

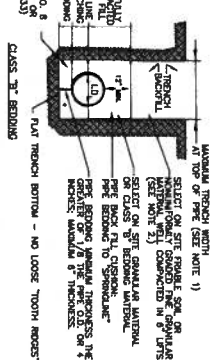

- TRENCH AND BEDDING NOTES:
 1. TRENCHES SHALL BE EXCAVATED TO THE PROPOSED FINISH GRADE OF THE PIPE.
 2. TRENCHES SHALL BE EXCAVATED TO THE PROPOSED FINISH GRADE OF THE PIPE.
 3. TRENCHES SHALL BE EXCAVATED TO THE PROPOSED FINISH GRADE OF THE PIPE.
 4. TRENCHES SHALL BE EXCAVATED TO THE PROPOSED FINISH GRADE OF THE PIPE.
 5. TRENCHES SHALL BE EXCAVATED TO THE PROPOSED FINISH GRADE OF THE PIPE.

18 WATERLINE TRENCH & BEDDING
(CITY OF GERRARD DETAIL)

HYDRANT ASSEMBLY DETAIL

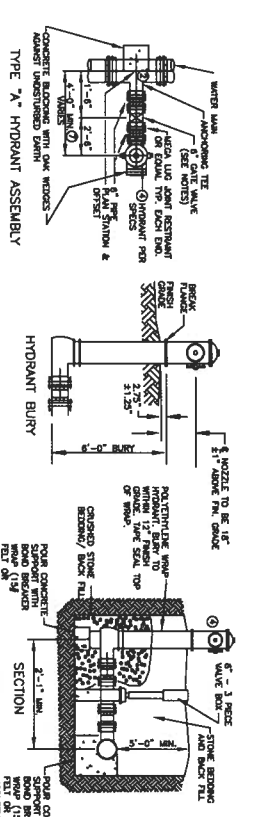

1. HYDRANT SHALL BE SET TO THE PROPOSED FINISH GRADE OF THE PIPE.
 2. HYDRANT SHALL BE SET TO THE PROPOSED FINISH GRADE OF THE PIPE.
 3. HYDRANT SHALL BE SET TO THE PROPOSED FINISH GRADE OF THE PIPE.
 4. HYDRANT SHALL BE SET TO THE PROPOSED FINISH GRADE OF THE PIPE.
 5. HYDRANT SHALL BE SET TO THE PROPOSED FINISH GRADE OF THE PIPE.

20 HYDRANT ASSEMBLY
(CITY OF GERRARD DETAIL)

WATER DISTRIBUTION MATERIAL SPECIFICATIONS

PIPE MATERIALS: ALL PIPE SHALL BE MANUFACTURED BY THE MANUFACTURER AND REFERRED TO AS THE "CONTRACTOR'S SPEC". THE CONTRACTOR SHALL BE RESPONSIBLE FOR OBTAINING THE MATERIALS AND REFERRED TO AS THE "CONTRACTOR'S SPEC". THE CONTRACTOR SHALL BE RESPONSIBLE FOR OBTAINING THE MATERIALS AND REFERRED TO AS THE "CONTRACTOR'S SPEC".

21 MISCELLANEOUS WATER LINE NOTES
(CITY OF GERRARD DETAIL)

TRENCH & BEDDING DETAILS

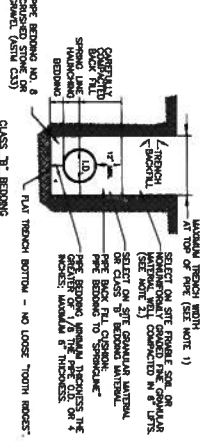

- TRENCH AND BEDDING NOTES:
 1. TRENCHES SHALL BE EXCAVATED TO THE PROPOSED FINISH GRADE OF THE PIPE.
 2. TRENCHES SHALL BE EXCAVATED TO THE PROPOSED FINISH GRADE OF THE PIPE.
 3. TRENCHES SHALL BE EXCAVATED TO THE PROPOSED FINISH GRADE OF THE PIPE.
 4. TRENCHES SHALL BE EXCAVATED TO THE PROPOSED FINISH GRADE OF THE PIPE.
 5. TRENCHES SHALL BE EXCAVATED TO THE PROPOSED FINISH GRADE OF THE PIPE.

22 SANITARY TRENCH & BEDDING
(CITY OF GERRARD DETAIL)

Length of Bedding	10	12	15	18	21	24
1.00	4.00	4.80	5.60	6.40	7.20	8.00
2.00	4.00	4.80	5.60	6.40	7.20	8.00
3.00	4.00	4.80	5.60	6.40	7.20	8.00
4.00	4.00	4.80	5.60	6.40	7.20	8.00
5.00	4.00	4.80	5.60	6.40	7.20	8.00
6.00	4.00	4.80	5.60	6.40	7.20	8.00
7.00	4.00	4.80	5.60	6.40	7.20	8.00
8.00	4.00	4.80	5.60	6.40	7.20	8.00
9.00	4.00	4.80	5.60	6.40	7.20	8.00
10.00	4.00	4.80	5.60	6.40	7.20	8.00

23 SANITARY STANDARD NOTES
(CITY OF GERRARD DETAIL)

SCB Solomon Corbett
BENZ www.benz.com
 Chicago 312.888.1100
 San Francisco 415.216.2450
 Architecture Planning Interior Design

NERF ASSOCIATES
 1810 EAST 17TH AVENUE
 DENVER, CO 80202

UTILITY DETAILS

Drawn By: JSD
 Checked By: JSD
 Project Number: 2012007

Sheet Number: **C7.1**

OBERLIN COLLEGE GATEWAY BUILDING
 Oberlin, Ohio
 2012 Renovation Contract Item

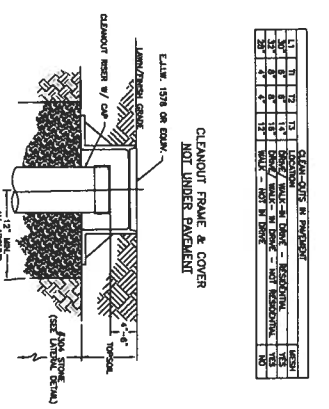

24 SANITARY SEWER SERVICE CLEANOUT
CITY OF GORDON BEHAVIOR

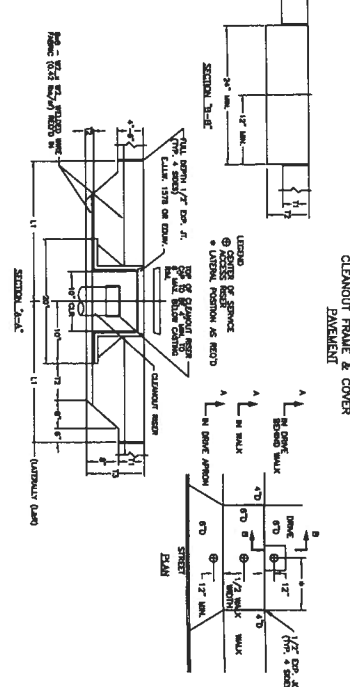

25 SANITARY SEWER SERVICE CONNECTION
CITY OF GORDON BEHAVIOR

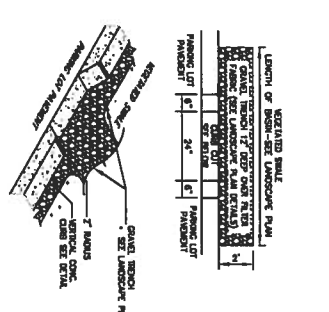

26 CURB CUT

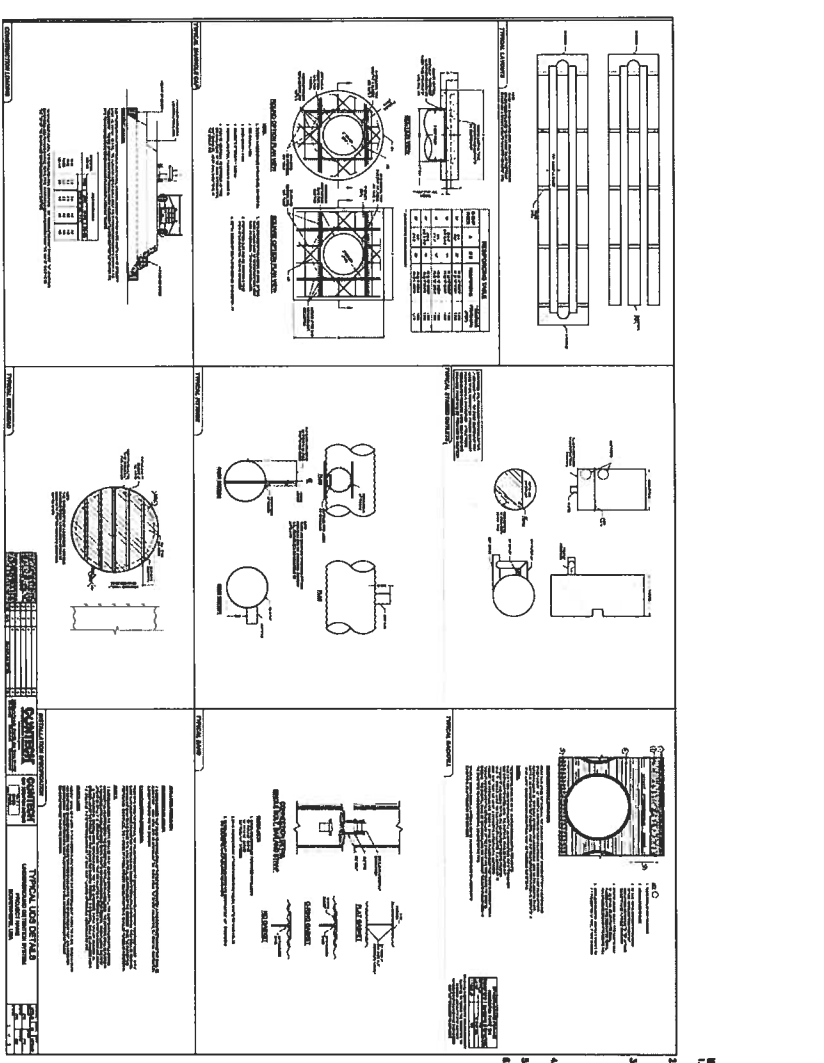
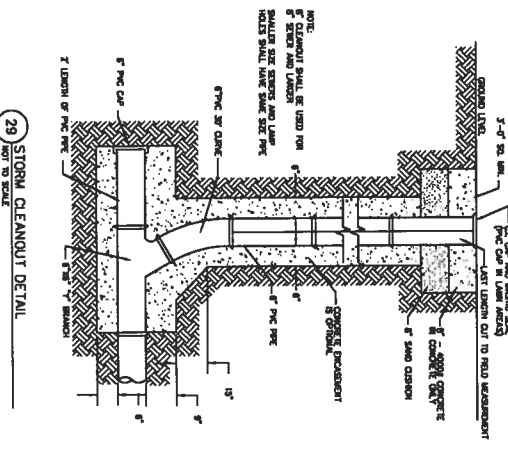
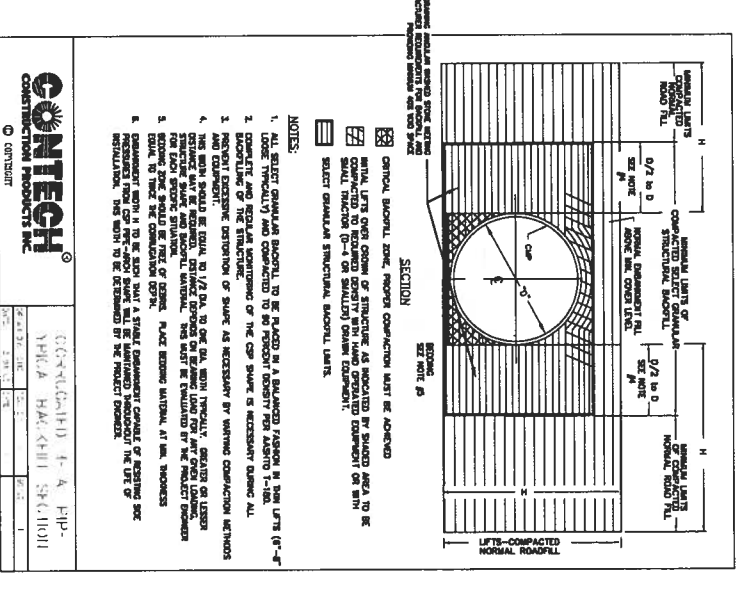

27 UNDERGROUND DETENTION STRUCTURE

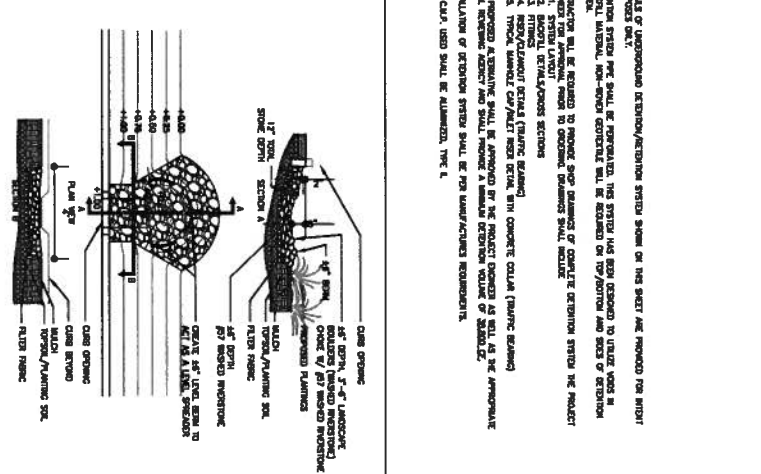

28 GRAVEL AT CURB OPENING

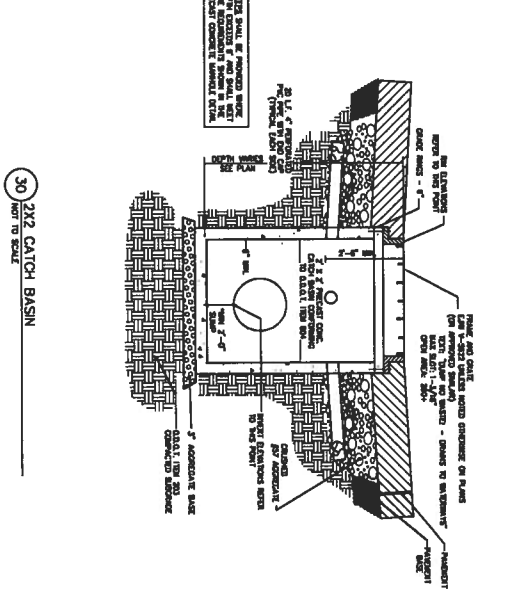

30 2X2 CATCH BASIN

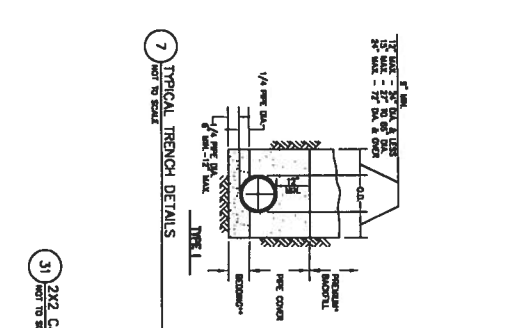

31 2X2 CATCH BASIN

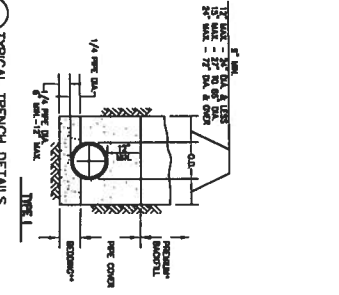

7 TYPICAL TRENCH DETAILS

DATE	REVISION

Oberlin, Ohio
 Oberlin College
 Gateway Building

SCB Solomon Cordwell Buenz
 www.scb.com
 Chicago 312.588.1100
 San Francisco 415.218.2450
NEPP ASSOCIATES

UTILITY DETAILS
 Drawn By: ASD
 Checked By: ASD
 Project Number: 2012007
C7.2

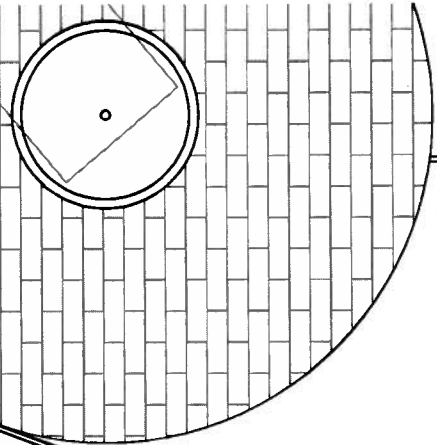

STAIRWELL

RETAIL
FFEL: 810.30

BANK
FFEL: 810.30

STAIRWELL
FFEL: 809.80

53'

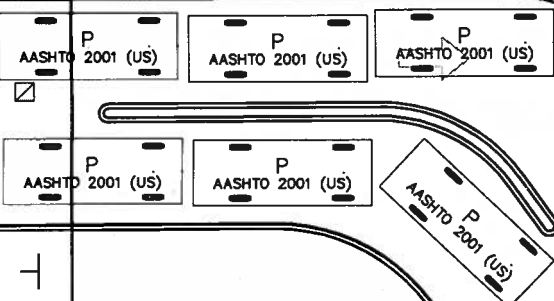

4

WV

CB

CO

P
Width : 7.00 feet
Track : 6.00
Lock to Lock Time : 6.0
Steering Angle : 31.6

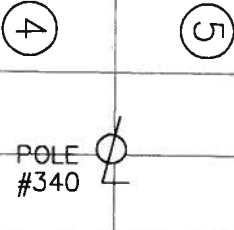
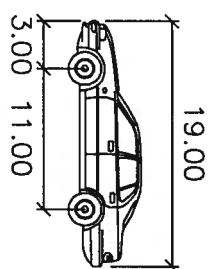

WALK



BANK DRIVE
STACKING FIGURE
GATEWAY BUILDING
OBERLIN, OHIO

NEFF & ASSOCIATES
Civil Engineers + Landscape Architects + Planners + Surveyors
6405 York Road | Parma Heights, Ohio 44130
Tel: 440.884.3100 | Fax: 440.884.6443
www.neff-assoc.com

Date: SEPT., 2013
Drawn By: JSO
Proj. No. 13640

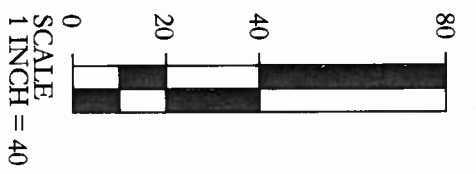
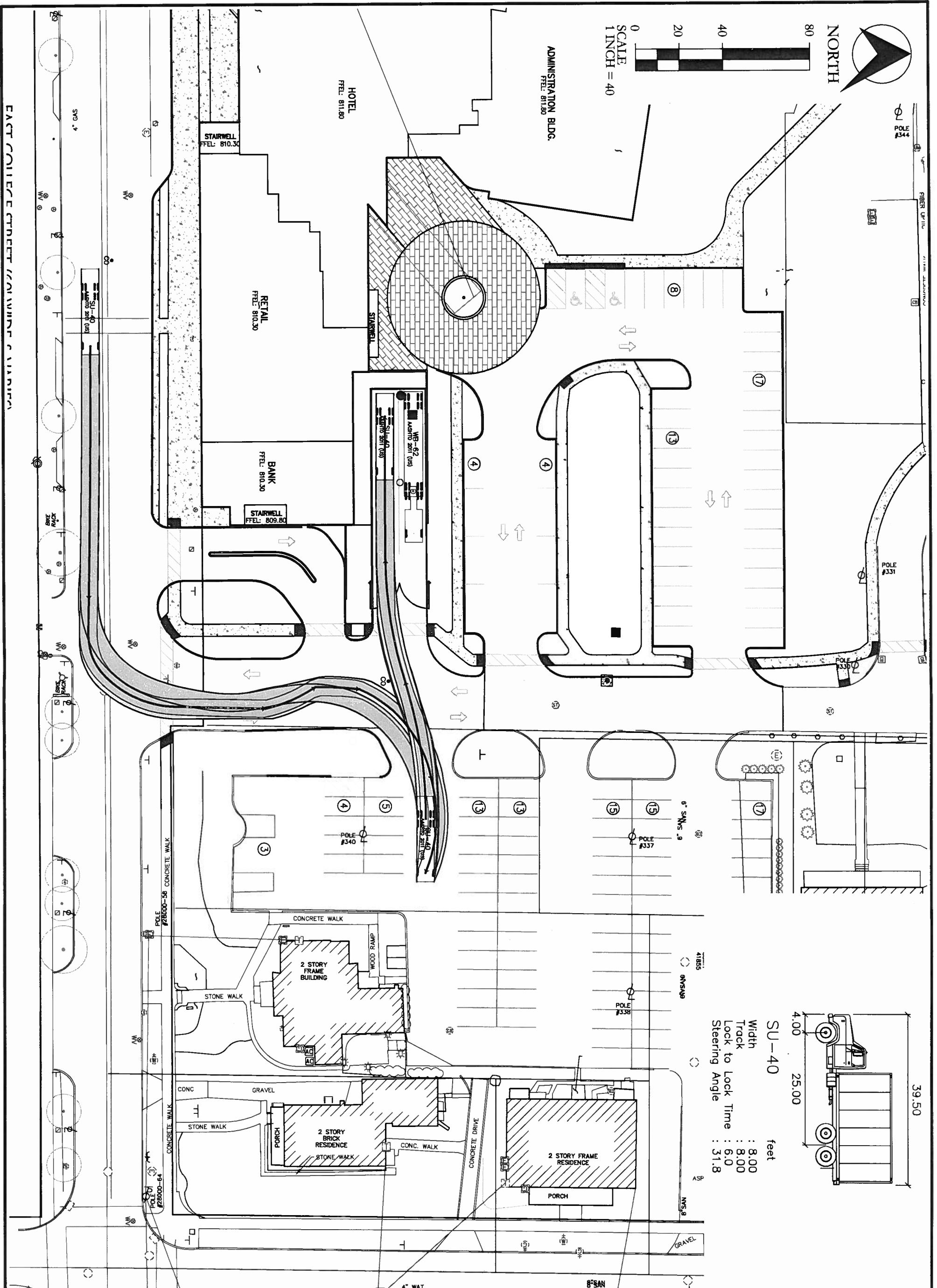

SU-40	feet
Width	: 8.00
Track	: 8.00
Lock to Lock Time	: 6.0
Steering Angle	: 31.8

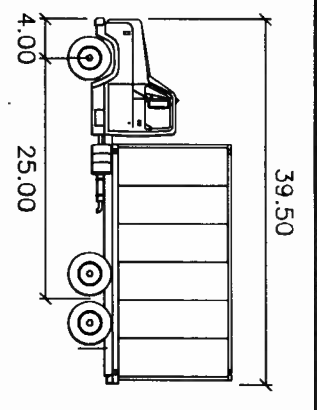

SMALL TRUCK - IN
TO LOADING BAY
GATEWAY BUILDING
OBERLIN, OHIO

Date: SEPT., 2013

Drawn By: JSO

Proj. No. 13640

2A

EAST COLLEGE STREET (CONVINCING VARIANCE)

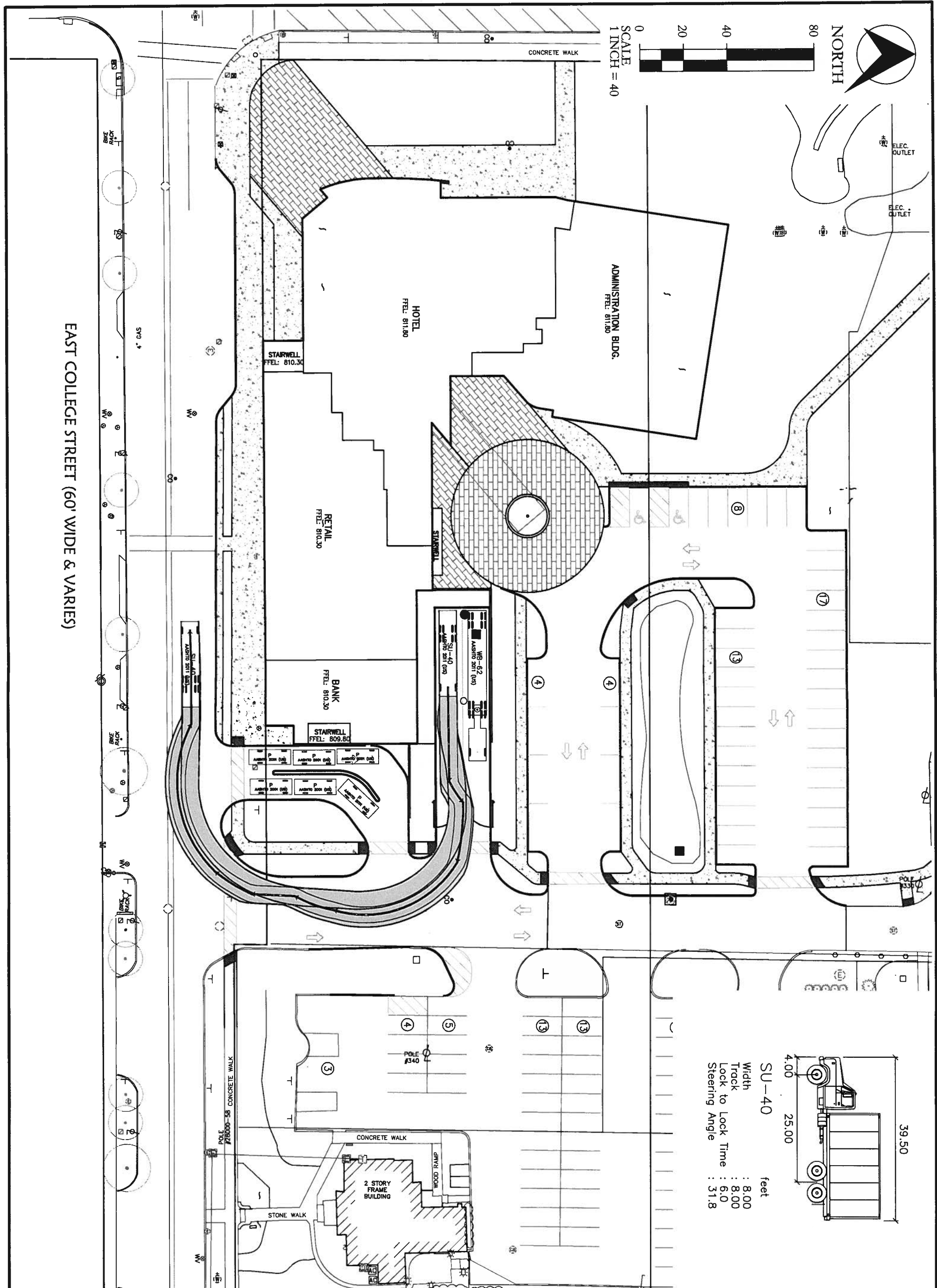

SMALL TRUCK - OUT SOUTH
FROM LOADING BAY
GATEWAY BUILDING
OBERLIN, OHIO

Date: SEPT, 2013
Drawn By: JSO
Proj. No. 13640

NEFF
& ASSOCIATES

Civil Engineers + Landscape Architects + Planners + Surveyors
6405 York Road | Parma Heights, Ohio 44130
Tel: 440.884.3100 | Fax: 440.884.6443
www.neff-assoc.com

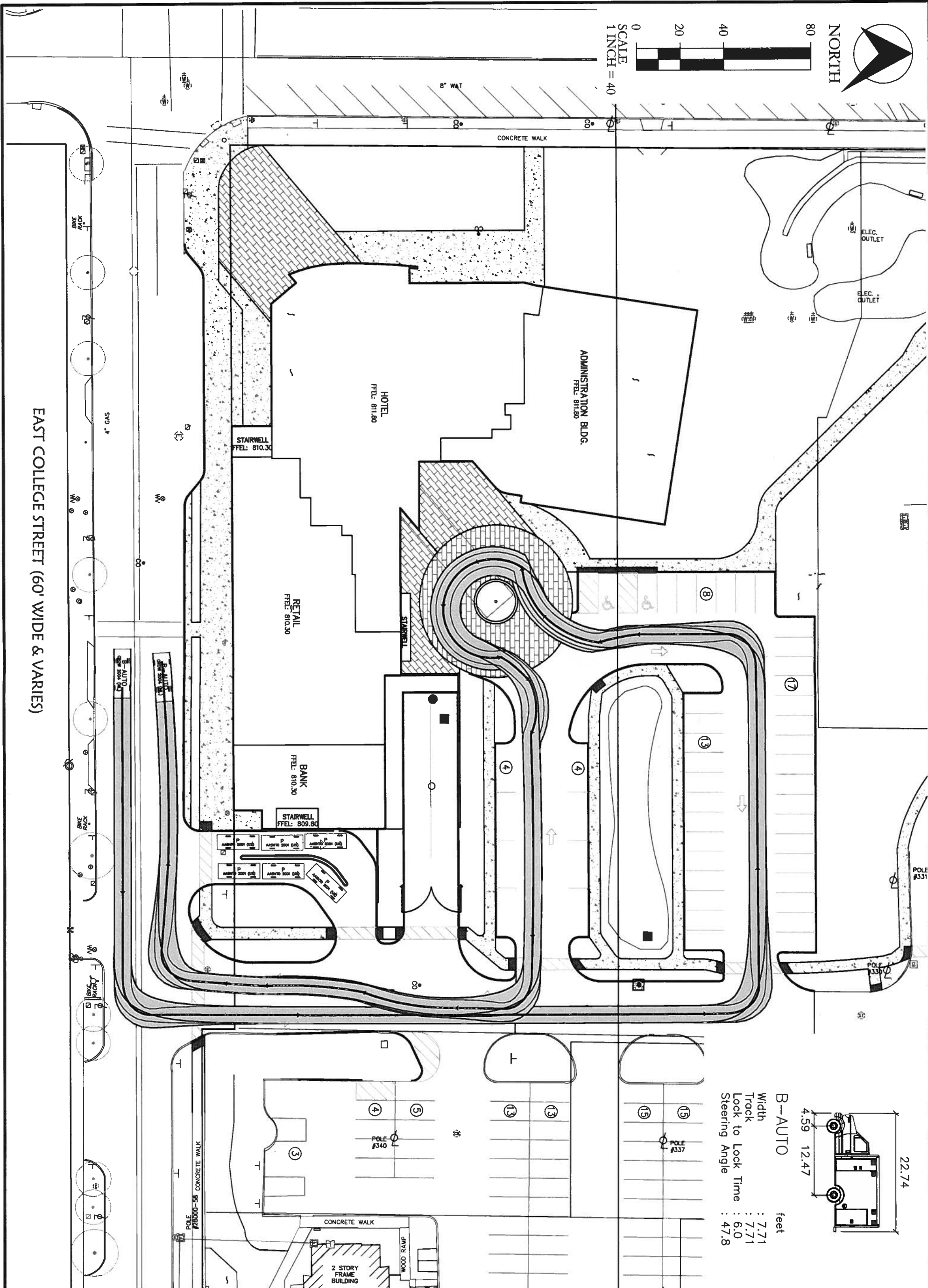

EAST COLLEGE STREET (60' WIDE & VARIES)

B-AUTO
 Width : 7.71 feet
 Track : 7.71 feet
 Lock to Lock Time : 6.0
 Steering Angle : 47.8

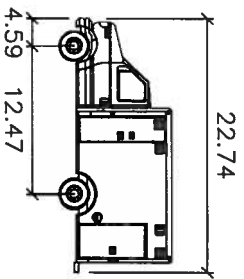

EMERGENCY ACCESS
 AMBULANCE THROUGH SITE
 GATEWAY BUILDING
 OBERLIN, OHIO

Civil Engineers + Landscape Architects + Planners + Surveyors
 6405 York Road | Parma Heights, Ohio 44130
 Tel: 440.884.3100 | Fax: 440.884.6443
 www.neff-assoc.com

Date: SEPT., 2013

Drawn By: JSO

Proj. No. 13640

3A

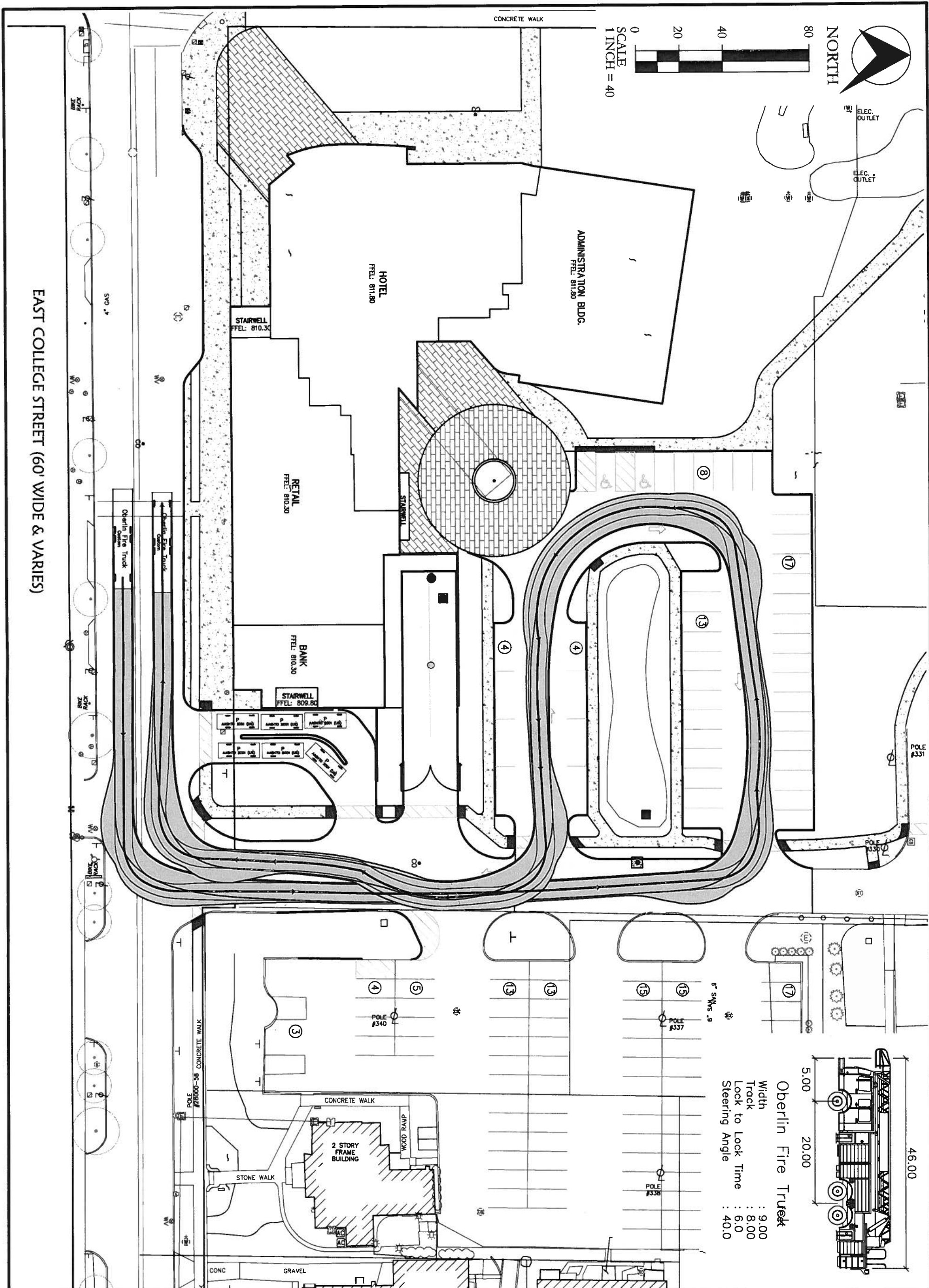

EMERGENCY ACCESS
FIRE TRUCK THROUGH SITE
GATEWAY BUILDING
OBERLIN, OHIO

NEFF
& ASSOCIATES

Civil Engineers + Landscape Architects + Planners + Surveyors
6405 York Road | Parma Heights, Ohio 44130
Tel: 440.884.3100 | Fax: 440.884.6443
www.neff-assoc.com

Date: SEPT., 2013

Drawn By: JSO

Proj. No. 13640

3B

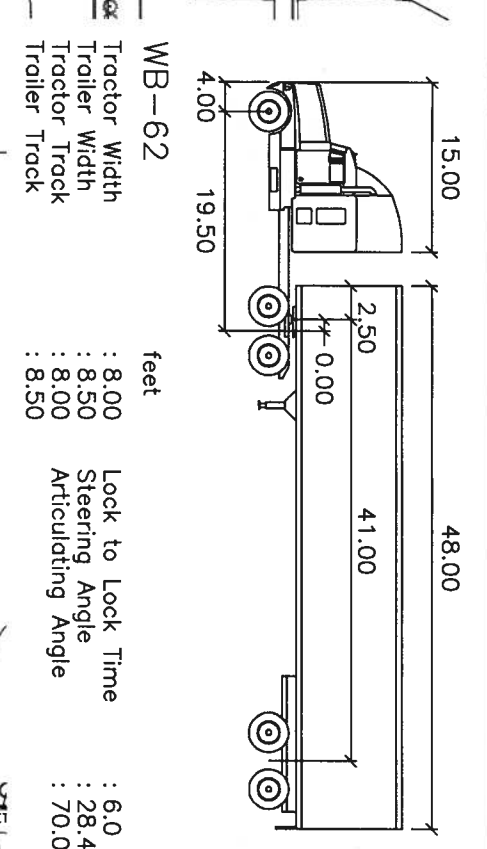
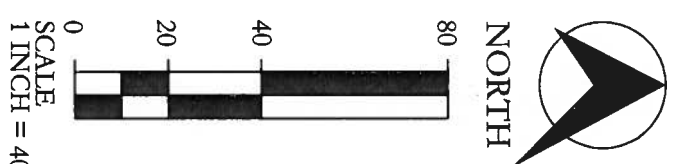
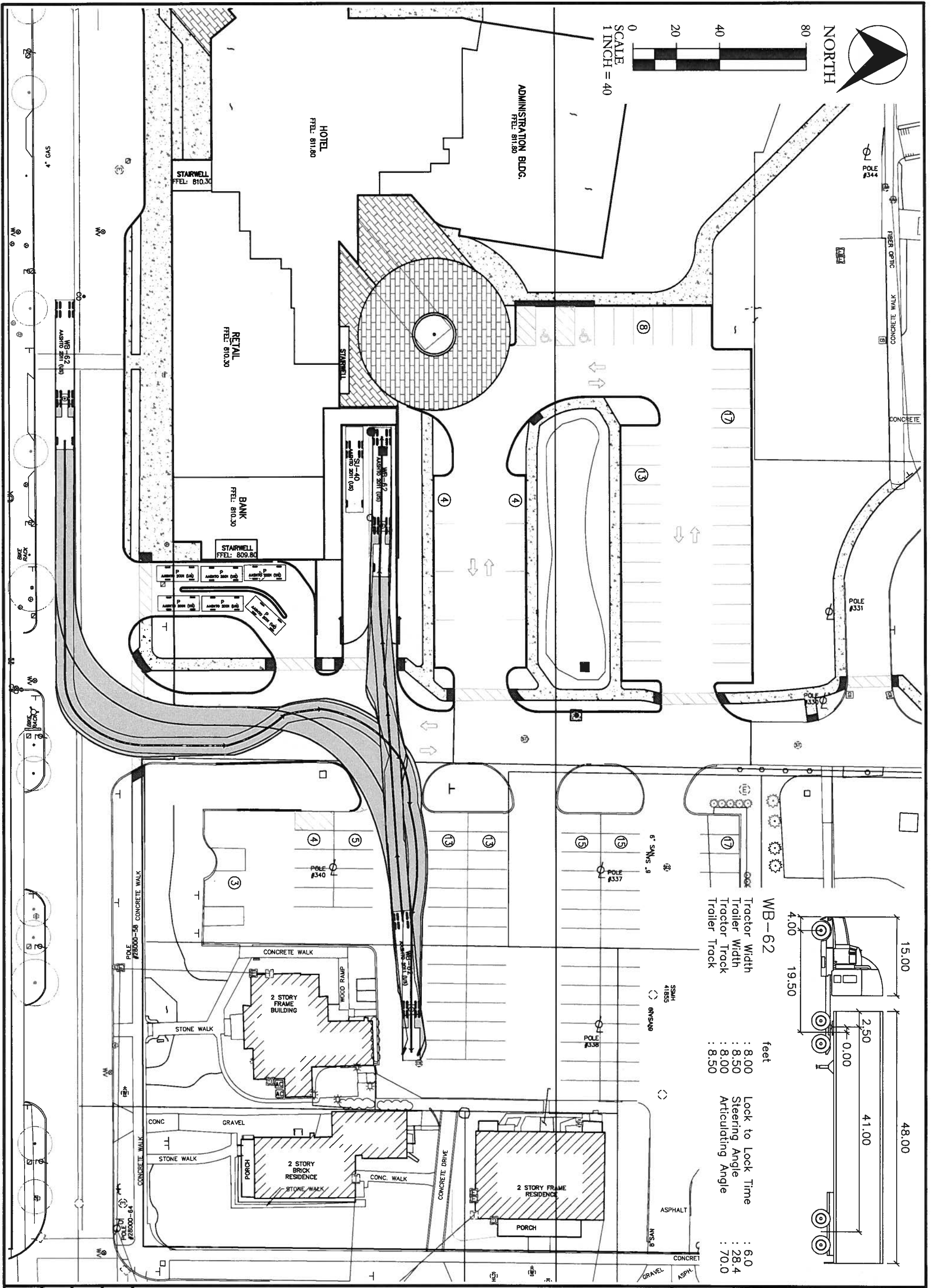

LARGE TRUCK ACCESS IN
TO LOADING BAY
GATEWAY BUILDING
OBERLIN, OHIO

NEFF
& ASSOCIATES

Civil Engineers + Landscape Architects + Planners + Surveyors
6405 York Road | Parma Heights, Ohio 44130
Tel: 440.884.3100 | Fax: 440.884.6443
www.neff-assoc.com

Date: SEPT., 2013
Drawn By: JSO
Proj. No. 13640
4A

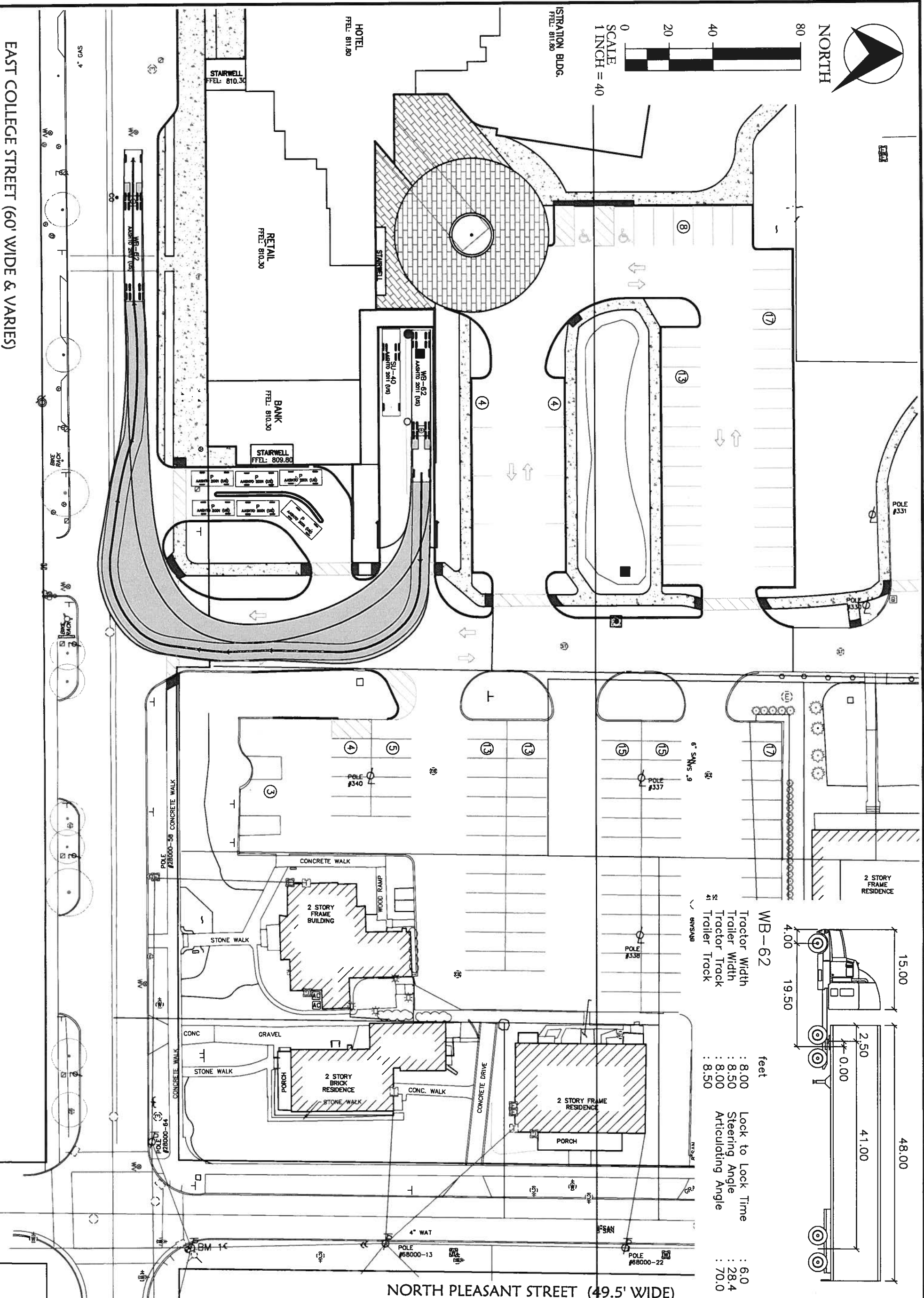
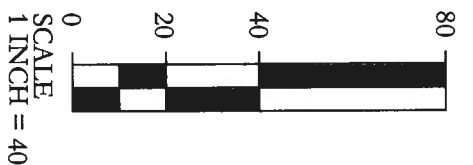

WB-62	feet
Tractor Width	: 8.00
Tractor Width	: 8.50
Tractor Track	: 8.00
Tractor Track	: 8.50
Lock to Lock Time	: 6.0
Steering Angle	: 28.4
Articulating Angle	: 70.0

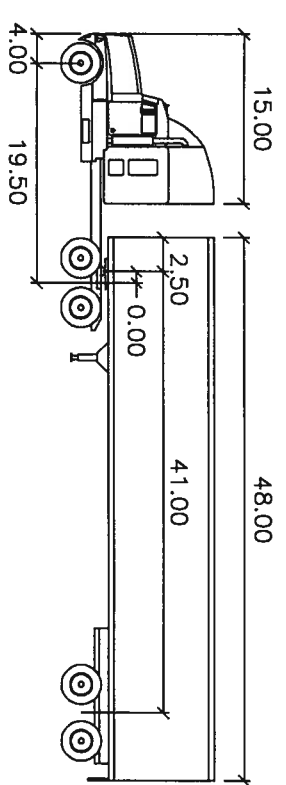

LARGE TRUCK ACCESS OUT
FROM LOADING BAY
GATEWAY BUILDING
OBERLIN, OHIO

NEFF
& ASSOCIATES

Civil Engineers + Landscape Architects + Planners + Surveyors
6405 York Road | Parma Heights, Ohio 44130
Tel: 440.884.3100 | Fax: 440.884.6443
www.neff-assoc.com

Date: SEPT., 2013
Drawn By: JSO
Proj. No. 13640
4B

EAST COLLEGE STREET (60' WIDE & VARIES)

NORTH PLEASANT STREET (49.5' WIDE)

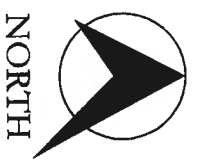

EAST COLLEGE STREET (60' WIDE & VARIES)

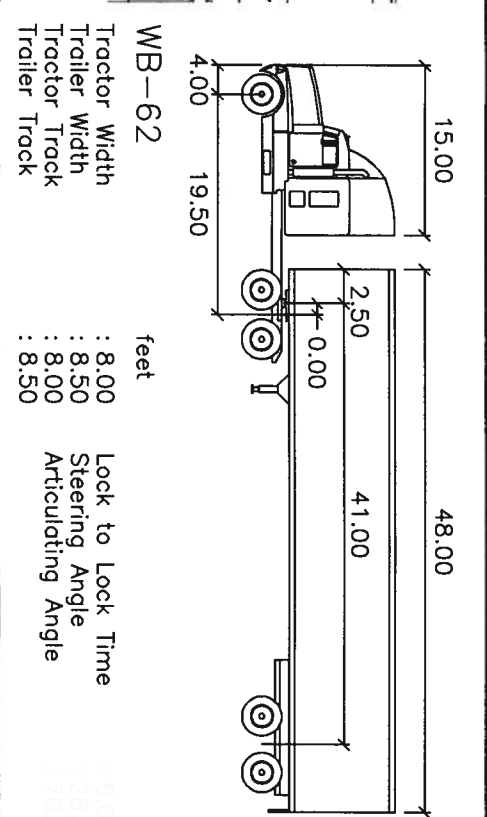
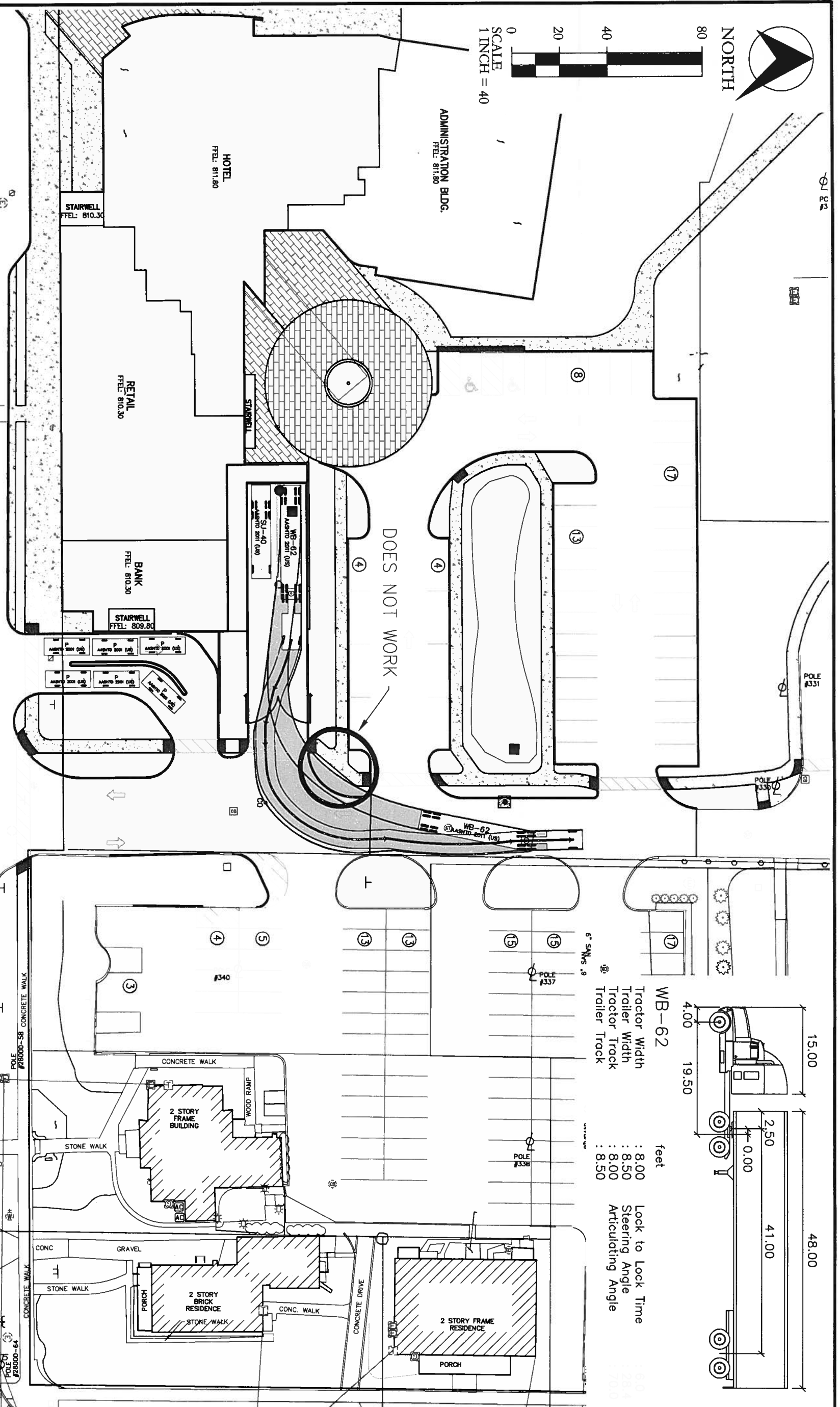

LARGE TRUCK ACCESS OUT - ALT
 FROM LOADING BAY
 GATEWAY BUILDING
 OBERLIN, OHIO



Date: SEPT., 2013

Drawn By: JSO

Proj. No. 13640

4C

OBERLIN COLLEGE GATEWAY BUILDING

Site Plan Review - July 17, 2013





© 2013 Solomon Cordwell Buenz

ARTIST

ARCHITECT

**VIEW OF SOUTH-WEST CORNER
GATEWAY BUILDING**
Oberlin College

07.17.2013
2012007





© 2013 Solomon Cordwell Buenz

0717

**VIEW OF WEST FACADE
GATEWAY BUILDING**
Oberlin College

07172013
2012007





© 2013 Solomon Cordwell Buenz

2.50m

1:1000

**VIEW OF NORTH FACADE
GATEWAY BUILDING**
Oberlin College

07.17.2013
2012007





Exterior Aluminum Venetian Blinds
(E-SSCR-01)

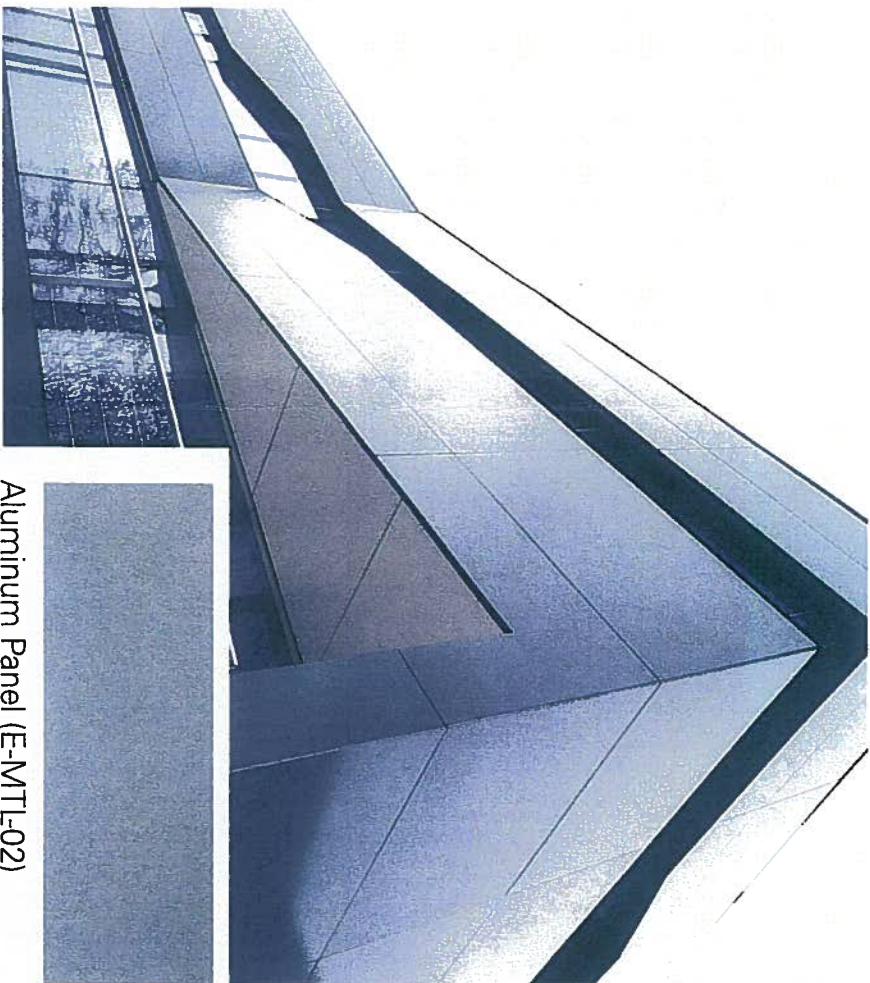

Aluminum Panel (E-MTL-02)



Zinc Panel (E-MTL-01)

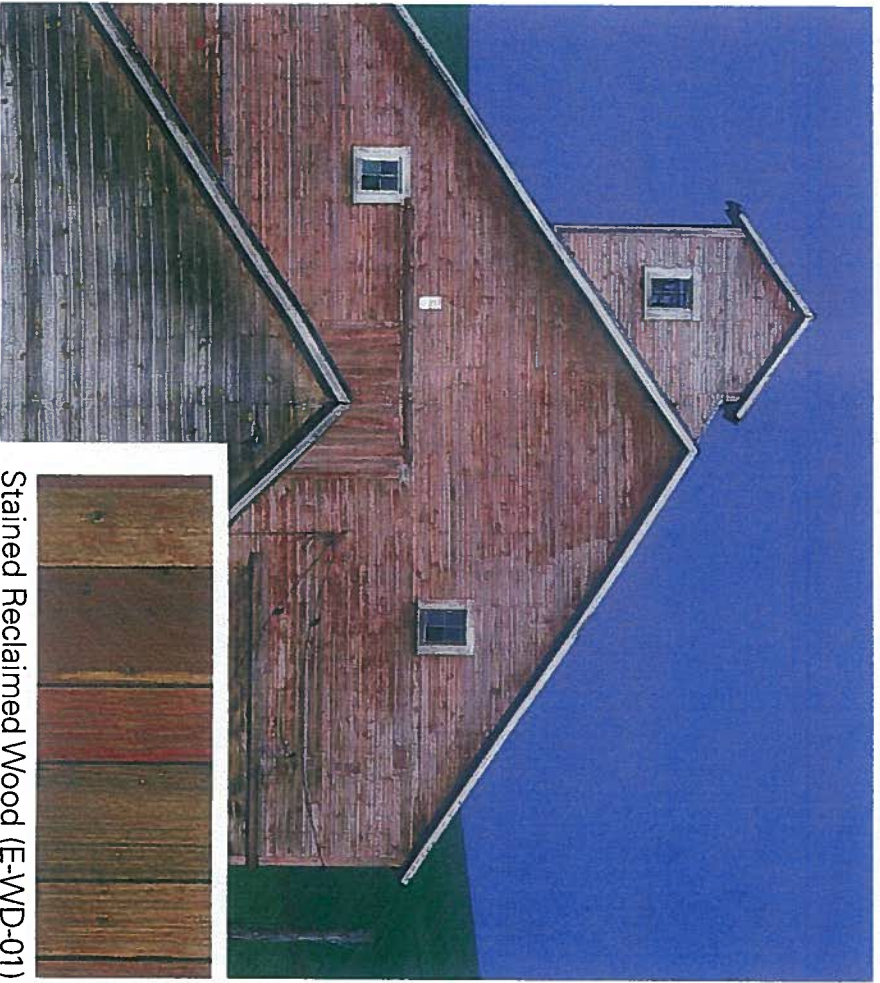

Stained Reclaimed Wood (E-WD-01)



Extruded Glass Fiber Concrete-
Panel (E-CPL-01)

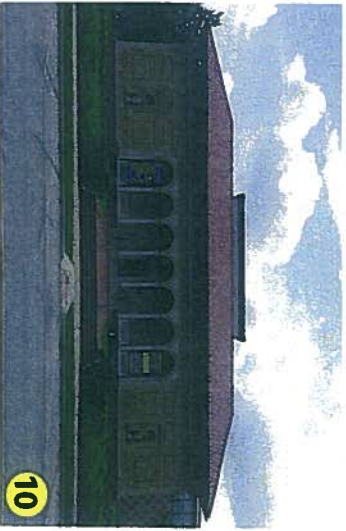
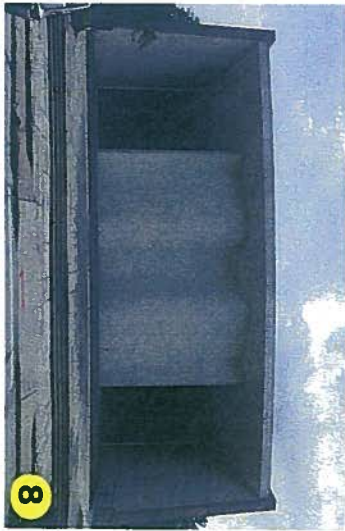
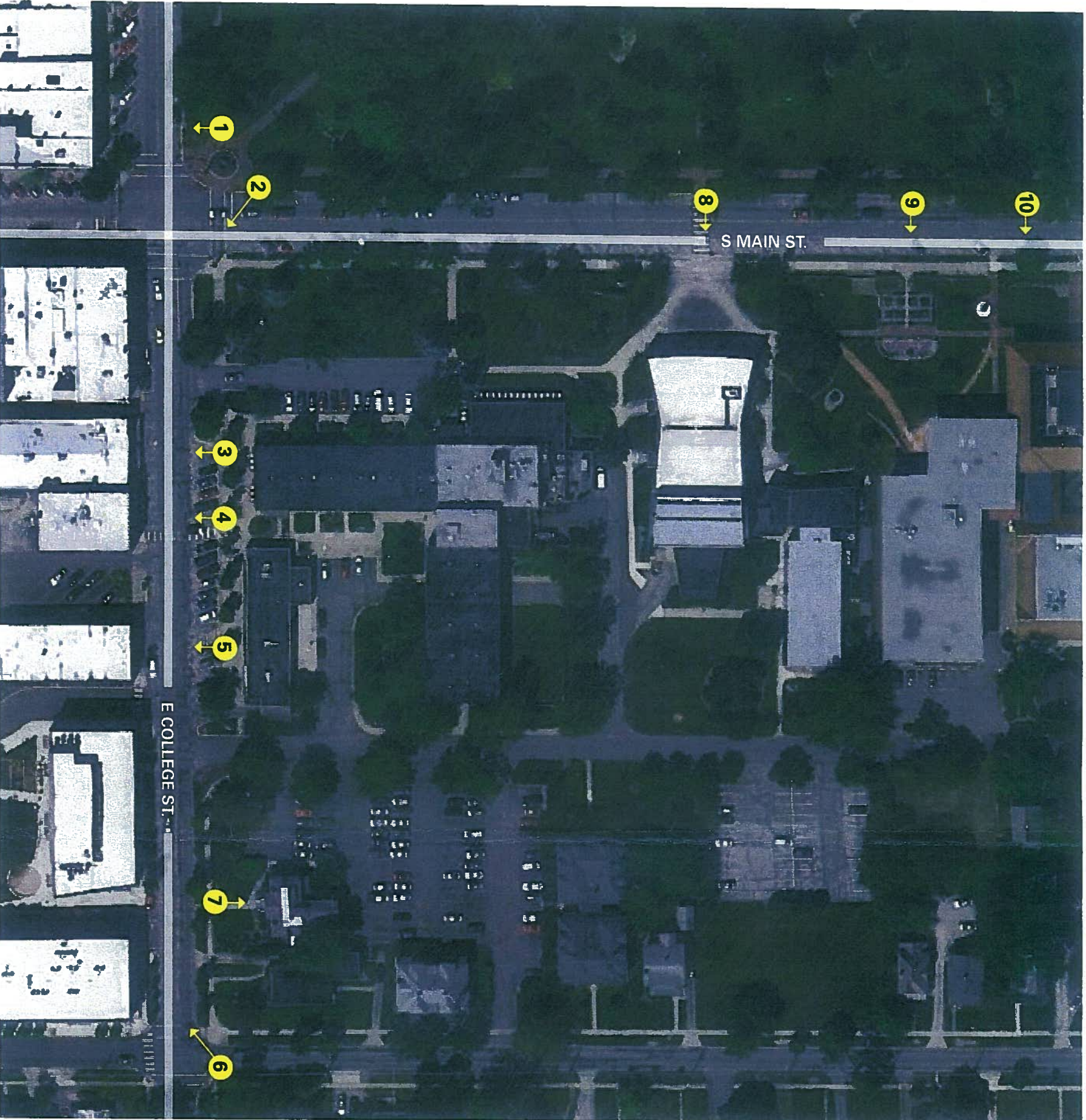

Oberlin Gateway Building

	Proposed Building based on Chapter 1349, tables 1, 3 & 5	Parking requirements based on Chapter 1349, tables 1, 3 & 5	Utilization Rate	Total Parking based on Utilization and Chapter 1349, tables 1, 3 & 5.	Parking calculation based on Zoning Ordinance Chapter 1349, tables 1, 3 & 5.	C1 Zoning Requirements (none required per 1349.01(d))
PARKING ANALYSIS - DAYTIME						
Hotel (Rooms)	67	67	70%	47	1 parking stall per room	0
Meeting Rooms (Seats)	320	80	70%	56	.25 parking stalls per person	0
Office (SF)	14,293 sf	50	60%	30	3.5 parking stalls per 1,000 sf	0
Restaurant/ Bar (SF)	2,597 sf	52	70%	36	20 parking stalls per 1,000 sf	0
Retail (SF)	8,980 sf	36	50%	18	4 parking stalls per 1,000 sf	0
Parking Spaces						
Area A	29					
Area B	96					
* Area C	76					
* Area D	20					
Total Parking Spaces	221	285		187		

	Proposed Building based on Chapter 1349, tables 1, 3 & 5	Parking requirements based on Chapter 1349, tables 1, 3 & 5	Utilization Rate	Total Parking based on Utilization and Chapters 1349, tables 1, 3 & 5.	Parking calculation based on Zoning Ordinance Chapter 1349, tables 1, 3 & 5.	C1 Zoning Requirements (none required per 1349.01(d))
PARKING ANALYSIS - NIGHTTIME						
Hotel (Rooms)	67	67	70%	47	1 parking stall per room	0
Meeting Rooms (Seats)	320	80	70%	56	.25 parking stalls per person	0
Restaurant/ Bar (SF)	2,597 sf	52	70%	36	20 parking stalls per 1,000 sf	0
Jazz Venue(SF)	2,345 sf	23	70%	16	10 parking stalls per 1,000 sf	0
Parking Spaces						
Area A	29					
Area B	96					
* Area C	76					
* Area D	20					
Total Parking Spaces	221	222		156		

* Projected additional spaces